

pneumatic
multi-disc brakes



turborex

 **Renova**
WE NEVER LOSE CONTROL

the new patented
turborex brake
technology



paper



flexographic and printing



corrugator

turborex

the design that completely
changes the concept in
web tension controls

Historically brakes have been chosen with only torque performance in mind. Little attention has been paid to the longer term problems of excessive disc and pad wear causing localised dust pollution and loss of tension control due to overheating. Turborex can achieve high torque values combined with minimal wear and heat generation not previously possible with a single disc brake.

paper

Absolute stability in tension control at any speed.

For unwind stands on slitters and sheeters. Turborex is capable of running 24 hours a day, 7 days a week with consistent brake performance in the most arduous of applications with the minimum of maintenance.

flexographic and printing

Variable torque applications.

On flexographic and gravure printing machines. Torque range capability from 1 - 500 with accurate tension control at the bottom or top of the tension range commonly found when in an emergency stop situation.

corrugator

Virtually no maintenance with minimal pad wear.

On corrugating machines. Turborex drastically reduces machine downtime. 20+ Conventional single disc brakes on a corrugating machine cause excessive downtime due to multiple pad changes each year. Turborex pads are exposed to far lower running temperatures which in turn means the pressure applied to the pad to achieve the required tension is far lower. The combination of these 2 factors drastically reduces machine down time through extended brake pad life.

5 years maintenance free

Please check terms and conditions
on instructions manual



old mono-disc brake

Traditional mono-disc limitation.

Pneumatic control: High numbers of pistons and pads all operating together are difficult to control accurately.

Variable tension control causes changing of results: Disc wear and glazing of pads result in variable friction values within the brake causing variable web tension results.

Excessive pad wear cannot be reduced: High pad wear means more maintenance stops causing excessive machine downtime.

Dust pollution: High pads wear generates high levels of dust which enter the atmosphere around the machine or more seriously the product being converted

Poor control at high speed: Speeds over 300m/min are difficult to control.

Manual selection of pads: Another function for the operator to control or sometimes to forget altogether.

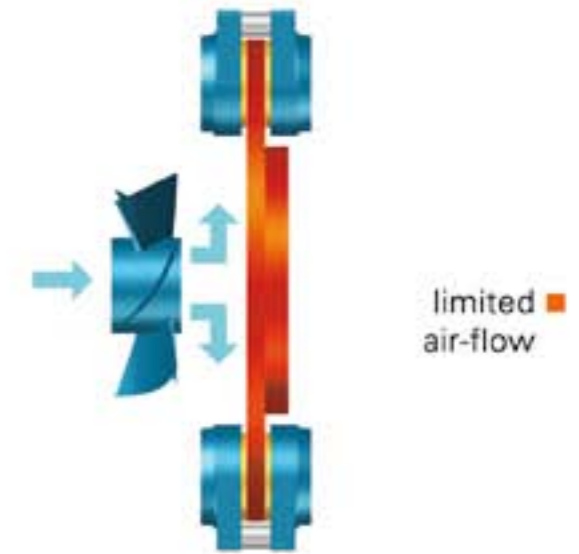

new Turborex multi-disc brake

Innovative turborex multi-disc brake advantages.

Pneumatic control: Pad stability with equal push force.

Precise, repeatable tension control: Drastically reduced operating temperatures ensure the discs and pads do not overheat causing a loss of tension consistency.

Massively reduced pad wear: Reduced heat and reduced pistons push pressure mean pad wear is virtually eliminated. Reduction of maintenance requirements increase machine efficiency and running time.

Negligible dust: Reduced pad wear means greatly reduced dust. The Turborex can be fitted with PM10 rated filters for medical or food applications.

High speed capability: Production speeds of 1000m/min are possible due to low temperature and reduced disc diameter.

Automatic torque selection: Selematic sequential disc selector allows the full brake range to be exploited without operator manual selection. The system will switch in and out the required number of pads proportional to the air pressure applied to the brake.



the
difference

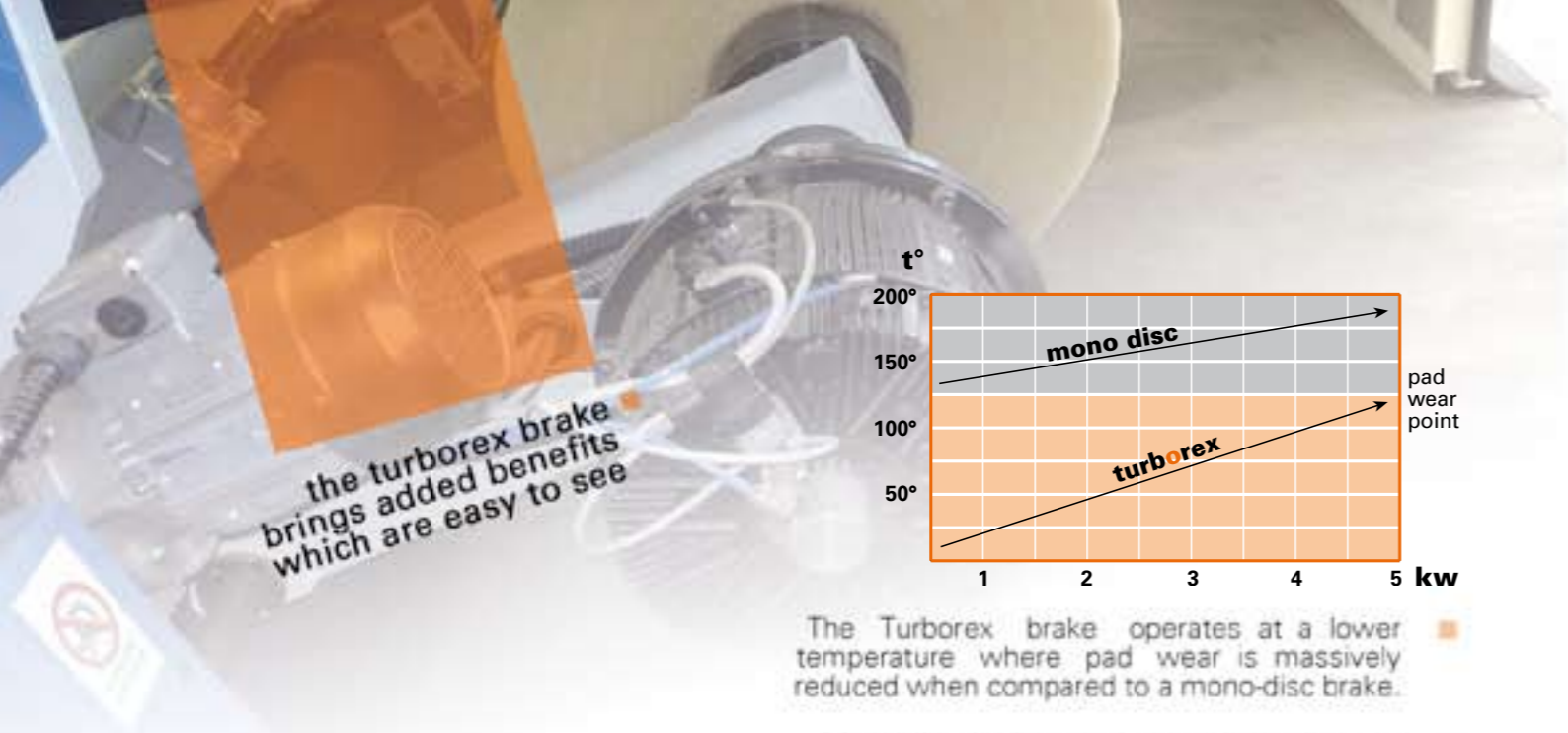

the turborex brake brings added benefits which are easy to see

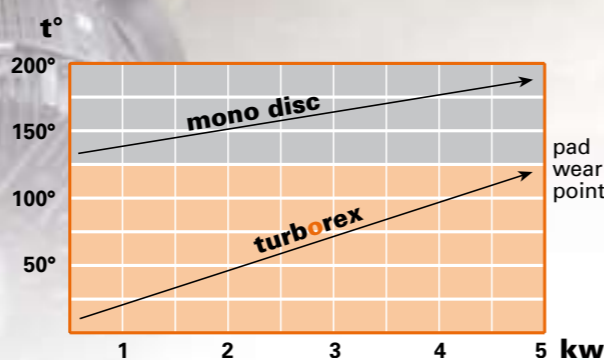

The Turborex brake operates at a lower temperature where pad wear is massively reduced when compared to a mono-disc brake.

Mono-disc brakes tend to work on the area above a temperature of 120° where excessive pad wear occurs.

old mono-disc cooling system

The mono-disc brake is a simple design incorporating 1 disc and several callipers. But performance is limited by heat, speed and pressure with no engineering upgrade possible.

- Cooling system only on 1 surfaces
- Disc diameter 250 mm
- Pads / disc pressure is 1:1

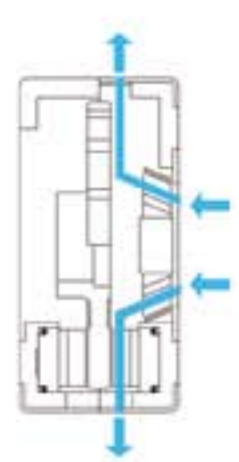

Heat dissipation

Temperature (°C)	monodisc (Kw)	turborex
120°	1	40°
150°	2	50°
200°	3	80°
	5	120°

new turborex multi-disc cooling system

With the multi-disc design the difference is unprecedented, the improvements are fantastic. The Turborex now offers a level of performance not previously possible.

- Cooling system on 8 surfaces
- Disc diameter 180 mm
- Pads / discs specific pressure is 1:3

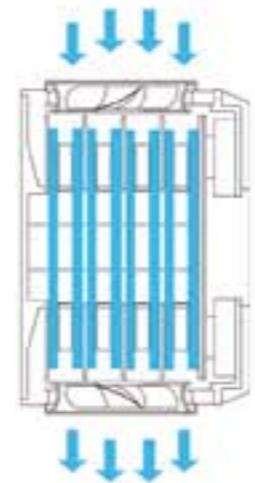

exploded view drawing

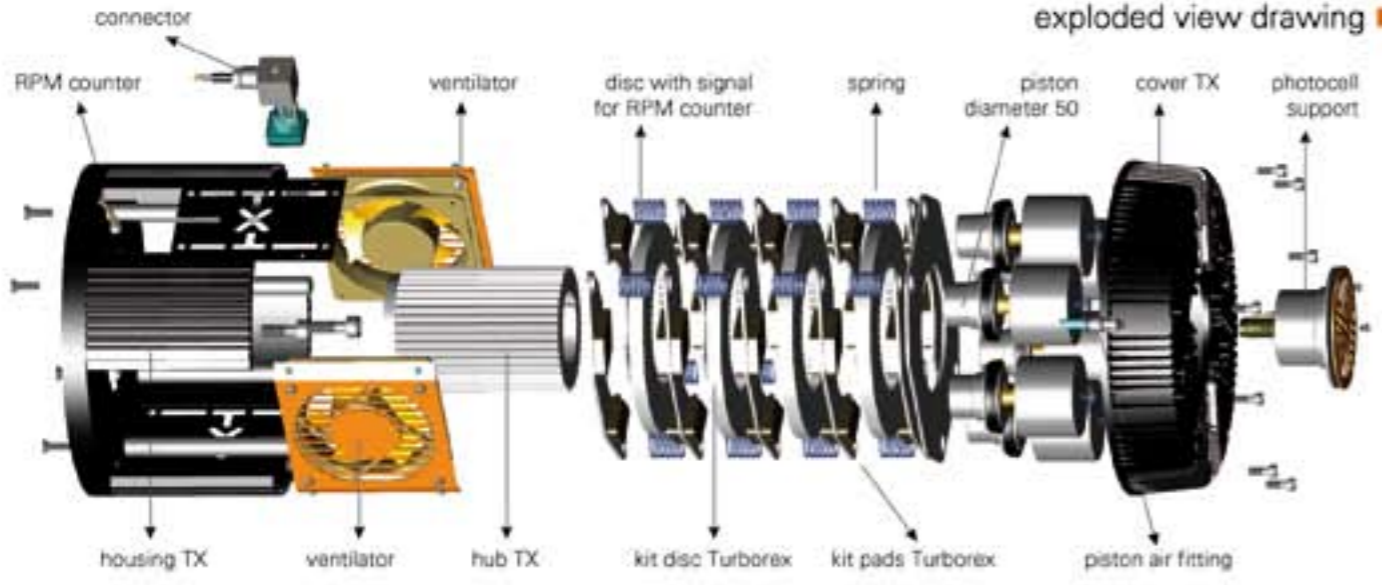

turborex TX110

model	torque (daNm) 6 ± 0,2 bar	heat dissipation stand. fan
tx 110.5	7 ± 0,3	1 kw
tx 110.10	11 ± 0,5	1 kw
tx 110.15	18 ± 0,7	1 kw
tx 110.25	25 ± 0,8	1 kw

turborex TX120

model	torque (daNm) 6 ± 0,2 bar	heat dissipation stand. fan
tx 120.7	11 ± 0,4	2 kw
tx 120.15	19 ± 0,6	2 kw
tx 120.30	30 ± 0,9	2 kw
tx 120.45	41 ± 1,2	2 kw

turborex TX170

model	torque (daNm) 6 ± 0,2 bar	heat dissipation stand. fan	hp fan	model	torque stage 1	stage 2	stage 3
tx 170.20	19 ± 0,6	3,5 kw	5 kw				
tx 170.40	37 ± 1,2	3,5 kw	5 kw				
tx 170.60	56 ± 1,8	3,5 kw	5 kw				
tx 170.75	74 ± 2,2	3,5 kw	5 kw	tx 170.75 V	37 ± 1,2	74 ± 2,2	

turborex TX180

model	torque (daNm) 6 ± 0,2 bar	heat dissipation stand. fan	hp fan	model	torque stage 1	stage 2	stage 3
tx 180.25	28 ± 1	4,5 kw	7 kw				
tx 180.50	53 ± 1,8	4,5 kw	7 kw				
tx 180.75	79 ± 2,6	4,5 kw	7 kw				
tx 180.100	106 ± 3,5	4,5 kw	7 kw	tx 180.100 V	53 ± 1,8	53 ± 1,8	106 ± 3,5
tx 180.150	159 ± 5,3	4,5 kw	7 kw	tx 180.150 V	53 ± 1,8	106 ± 3,5	159 ± 5,3

turborex TX240

model	torque (daNm) 6 ± 0,2 bar	heat dissipation stand. fan	hp fan	model	torque stage 1	stage 2	stage 3
tx 240.70	70 ± 2,3	9 kw	12 kw				
tx 240.100	102 ± 3,5	9 kw	12 kw				
tx 240.140	140 ± 4,3	9 kw	12 kw	tx 240.140 V	70 ± 2,3	70 ± 2,3	140 ± 4,3
tx 240.210	210 ± 6,8	9 kw	12 kw	tx 240.210 V	70 ± 2,3	140 ± 4,3	210 ± 6,8
tx 240.280	280 ± 8,3	9 kw	12 kw	tx 240.280 V	70 ± 2,3	210 ± 6,8	280 ± 8,3

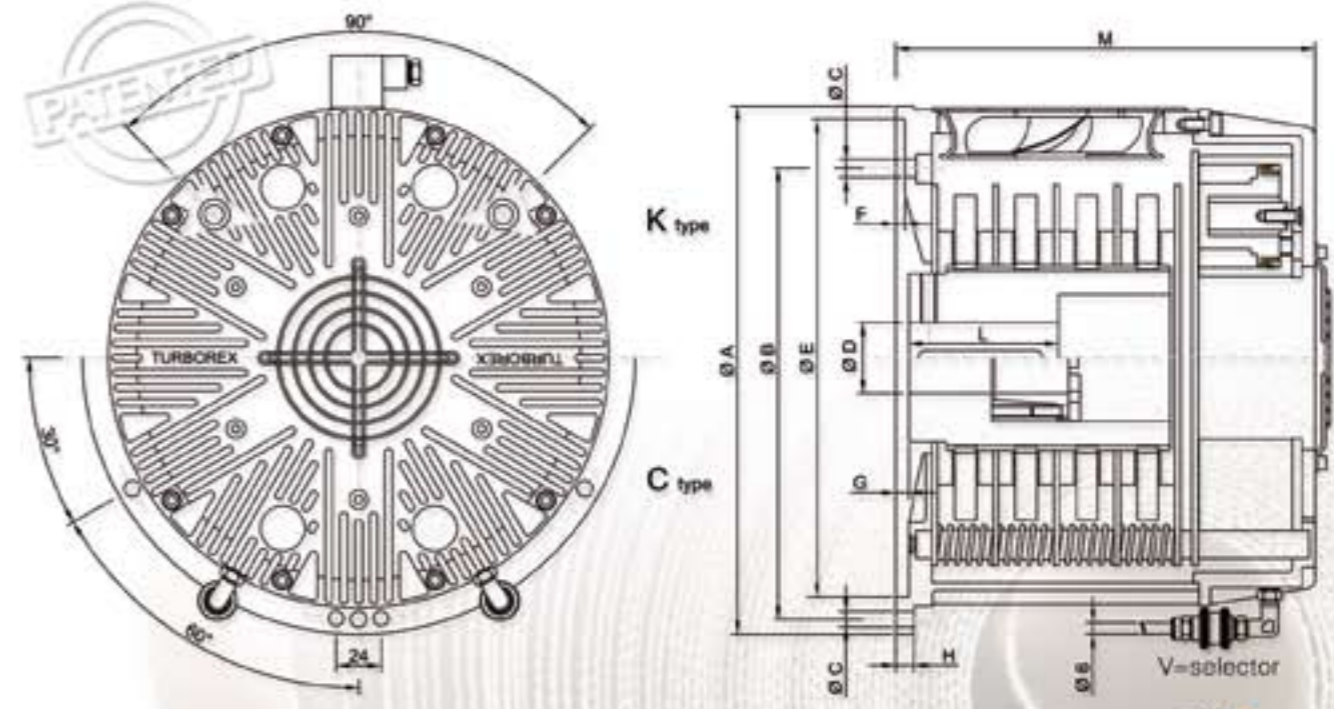

turborex TX dimensions (mm)

model	A	B	C	D max	E +0,05/+0,1	F	G	H	L	M
tx 110 C	220	212	6x6,5	40	132	3	3	12	50±62	115
tx 110 K	200	164	4x8,5	40	132	3	3	/	50±62	115
tx 120 C	220	212	6x6,5	40	132	3	3	12	50±87	134
tx 120 K	200	164	4x8,5	40	132	3	3	/	50±87	134
tx 170 C	296	280	6x8,5	60	256	5	5	14	60±107	187
tx 170 K	266	280	4x10,5	60	256	5	5	/	60±107	187
tx 180 C	296	280	6x8,5	60	306	5	5	14	60±145	216
tx 180 K	266	280	4x10,5	60	256	5	5	/	60±145	216
tx 180 Z	350	334	6x10,5	60	306	5	5	14	60±145	216
tx 240 K	340	322	4x12,5	90	306	5	8	/	60±156	232

turborex TX dimensions



wide torque range

turborex selematic

New Renova multi-disc Turborex brakes offer operators higher performance in web tension control.

Historically all the operators in the flexible laminates industry have been obliged to employ on their unwinders, traditional air cooled single disc calliper brakes, with problems of maintenance costs, wear, dust pollution, continuous adjustments to find the exact torque range at any work cycle, limits at high and medium linear speed.





After more than 30 years of research and development, Renova is proud to introduce new braking technology. New Turborex Selematic solves all these problems completely whilst offering these exclusive advantages: Higher constant thermal capacity for the uniform cooling of multiple low diameter discs.

Complete elimination of wear and dust pollution.

Incredible stability in regulation independent to speed.

New flexibility and accuracy in regulation.
Extended torque ratio from 1:30 to 1:500
with automatic regulation
for high accuracy.



-  soft
-  medium soft
-  medium hard
-  hard

the discs are automatically engaged proportionally to air pression

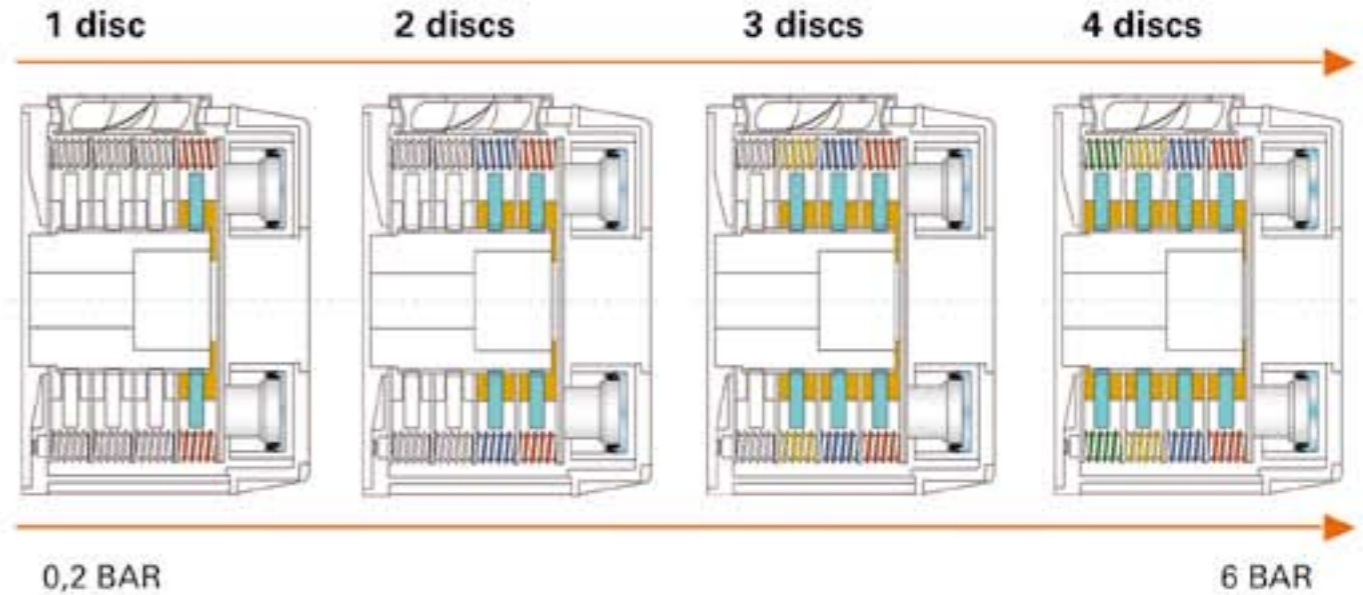

Turborex selematic features

- Automatic disc engagement wide range of torque - 1:500
- Incredible accuracy and precision in web tension control
- Double fan system to reduce temperatures
- Emergency stop always available
- Final solution to the powder pollution

When Selematic is incorporated in a Turborex brake the tension requirements for each material being processed, at the beginning for the roll, at the end of a roll and during an emergency stop situation can be accurately achieved via a single air supply without the need to manually select pads as would be necessary with a conventional single disc, multi pad brake design.



automatic disc engage

turborex selematic
technical data

turborex TS dimensions (mm)

model	A	B	C	D max	E +0,05/+0,01	F	G	H	L	M
ts 120 C	220	212	6x6,5	40	162	3	3	12	50÷87	134
ts 120 K	200	164	4x8,5	40	162	3	3	/	50÷87	134
ts 170 C	296	280	6x8,5	60	256	5	5	14	50÷107	187
ts 170 K	266	218	4x10,5	60	256	5	5	/	50÷107	187
ts 180 C	296	280	6x8,5	60	256	5	5	14	50÷145	216
ts 180 K	266	218	4x10,5	60	256	5	5	/	50÷145	216
ts 180 Z	350	334	6x10,5	60	306	5	5	14	50÷145	216
ts 240 K	340	322	4x12,5	90	306	5	8	/	50÷156	245

turborex TS120

model	torque (daNm)		heat dissipation	
	6 ÷ 0,2 bar	stand. fan	hp fan	hp fan
ts 120.7	11 ÷ 0,1	1,5 kw	2 kw	
ts 120.15	19 ÷ 0,15	1,5 kw	2 kw	
ts 120.30	29 ÷ 0,22	1,5 kw	2 kw	
ts 120.45	38 ÷ 0,3	1,5 kw	2 kw	

turborex TS180

model	torque (daNm)		heat dissipation	
	6 ÷ 0,2 bar	stand. fan	hp fan	hp fan
ts 180.25	28 ÷ 0,25	4,5 kw	7 kw	
ts 180.50	53 ÷ 0,45	4,5 kw	7 kw	
ts 180.75	79 ÷ 0,65	4,5 kw	7 kw	
ts 180.100	106 ÷ 0,87	4,5 kw	7 kw	
ts 180.150	159 ÷ 1,3	4,5 kw	7 kw	

turborex TS170

model	torque (daNm)		heat dissipation	
	6 ÷ 0,2 bar	stand. fan	hp fan	hp fan
ts 170.20	19 ÷ 0,15	3,5 kw	5 kw	
ts 170.40	37 ÷ 0,3	3,5 kw	5 kw	
ts 170.60	56 ÷ 0,45	3,5 kw	5 kw	
ts 170.75	74 ÷ 0,52	3,5 kw	5 kw	

turborex TS240

model	torque (daNm)		heat dissipation	
	6 ÷ 0,2 bar	stand. fan	hp fan	hp fan
ts 240.70	70 ÷ 0,5	9 kw	12 kw	
ts 240.100	102 ÷ 0,75	9 kw	12 kw	
ts 240.140	140 ÷ 1,2	9 kw	12 kw	
ts 240.210	210 ÷ 1,6	9 kw	12 kw	
ts 240.280	280 ÷ 2,4	9 kw	12 kw	

Procedure to dimension a turborex TX and turborex selematic brake for web tension applications.

Determining the max and min. torque (M_Tmax and M_Tmin)

■ $M_{Tmax} = \frac{T_{max} \cdot D_{max}}{2} = daNm$ _____

■ $M_{Tmin} = \frac{T_{min} \cdot d_{min}}{2} = daNm$ _____

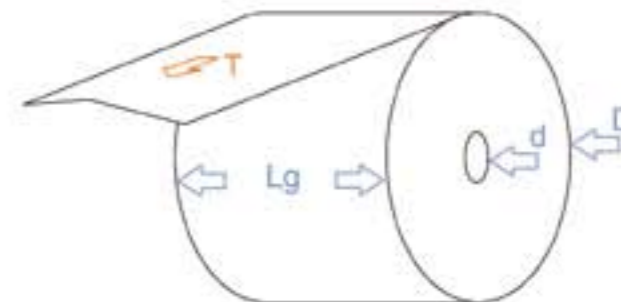

To determine the power to be dissipated (P)

■ $P = \frac{V_{max} \cdot T_{max}}{6000} = Kw$ _____

To determine the emergency stop torque (M_{te})

■ $M_{te} = \frac{m \cdot D \cdot V}{240 \cdot t} = daNm$ _____

m = roll weight
t = breaking torque
V = linear web speed m/min
T max (daN) = max tension Ts · lg max (cm)
T min (daN) = min tension Ts · lg min (cm)

Specific tension values for typical converting materials

Paper weight g/m ²	Tension daN·cm	Board weight g/m ²	Tension daN·cm
10 - 15	0,03 - 0,04	100 - 150	0,5 - 0,75
30 - 60	0,1 - 0,25	200 - 300	1 - 1,15
100 - 200	0,35 - 0,7	400 - 700	1,6 - 1,8

Cellophane:
0,0042 daN·cm μ of thickness

Polyethylene oriented / not oriented:
Ts 0,0025 / 0,0015 daN·cm μ of thickness

Polyethylene low / high density:
Ts 0,001 / 0,002 daN·cm μ of thickness

Aluminium mild:
0,001 daN·cm μ of thickness

Aluminium Hardened:
0,0035 daN·cm μ of thickness

Band aluminium:
0,1 - 0,2 daN for mm²

Band steel:
0,3 - 0,5 daN for mm²

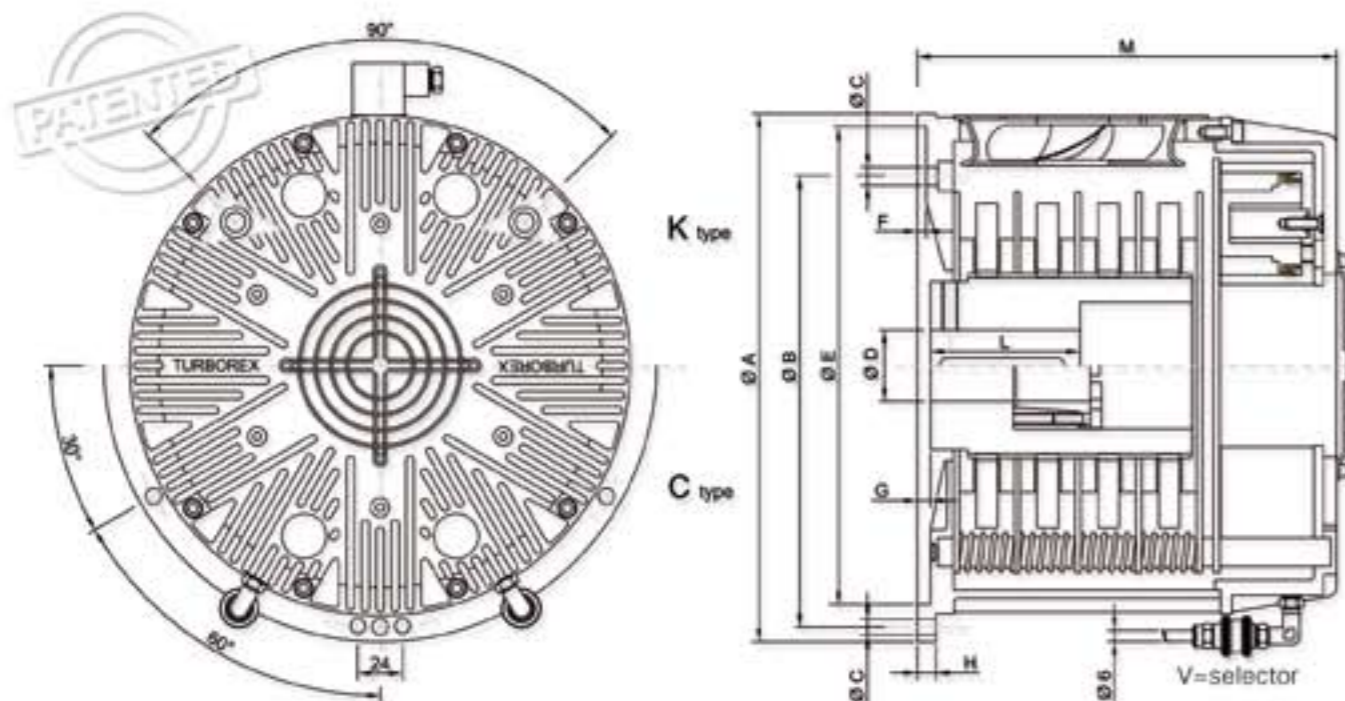

material
parameters



web tension control systems

Renova offers a wide product range covering the needs of manufactures and end users in the paper, corrugated cardboard, aluminum, adhesive tape, printing, textile and plastic industries



combirex

A mono-disc, multi-caliper, air-cooled brake. It reaches a maximum torque of 96 daNm and a power dissipation of 3kW. This CX model uses a 250mm disc and is available with up to 6 calipers.



powderex

Magnetic powder brakes with a torque range from 1-12 daNm. Radiator cooling or axial fan cooling.



mechanical chucks

Chucks for automatically centering a roll of any load and diameter. Available with or without the mechanical core ejector for core diameters of 3" to 12". Also available in a dual-diameter step chuck.

isomatic

Control Panel. Completely manage the process by configuring necessary functions on the display. Additional functions can be customized on your request. Advanced regulation capabilities.



sensorex

Load cells used to detect the web tension of a product. Available in different models, flange load cells and flange load cells with clearance hole, with loads from 5 to 600 daN.



e/p converter

Electropneumatic converter that converts an electrical signal into compressed air with a pressure directly proportional to the signal provided. It ensures accuracy in tension with power supply of 24 VDC and signal from 0 to 10 V.



reset

Digital measuring amplifier for strain gauge bridge, equipped with a 24-bit acquisition circuit with programmable gain, of 3 analog outputs to a control unit and a digital input for a reset of the outputs from remote.



moviroll

Pneumatic roll pusher that effortlessly moves rolls up to 10 t of weight.





Renova Srl is an Italian manufacturer and supplier of web tension control systems with four decades of application know-how.

With its wide product range, Renova extends its business to many application fields (paper, corrugated board, aluminum, tapes, printing & flexo, slitter, cutting machinery, tire) to the complete satisfaction of the most important machine builders and end users.

Renova's brakes, chucks, load cells, rollpushers, and web tension control panels are all 100% designed and made in Italy. This Renova choice is representative of a direct control of the entire production chain to ensure the highest product quality.



 **Renova**
WE NEVER LOSE CONTROL

Renova srl
via Pompeo Mariani 16
20128 Milano - Italy
phone: +39 02 27007394
fax: +39 02 25708635

web site: www.renova-srl.it
e-mail: info@renova-srl.it