

LE TRANSPORTEUR A ROULEAUX

THE ROLLER CONVEYOR

Des rouleaux adaptés
à vos besoins

Rollers adapted to your needs

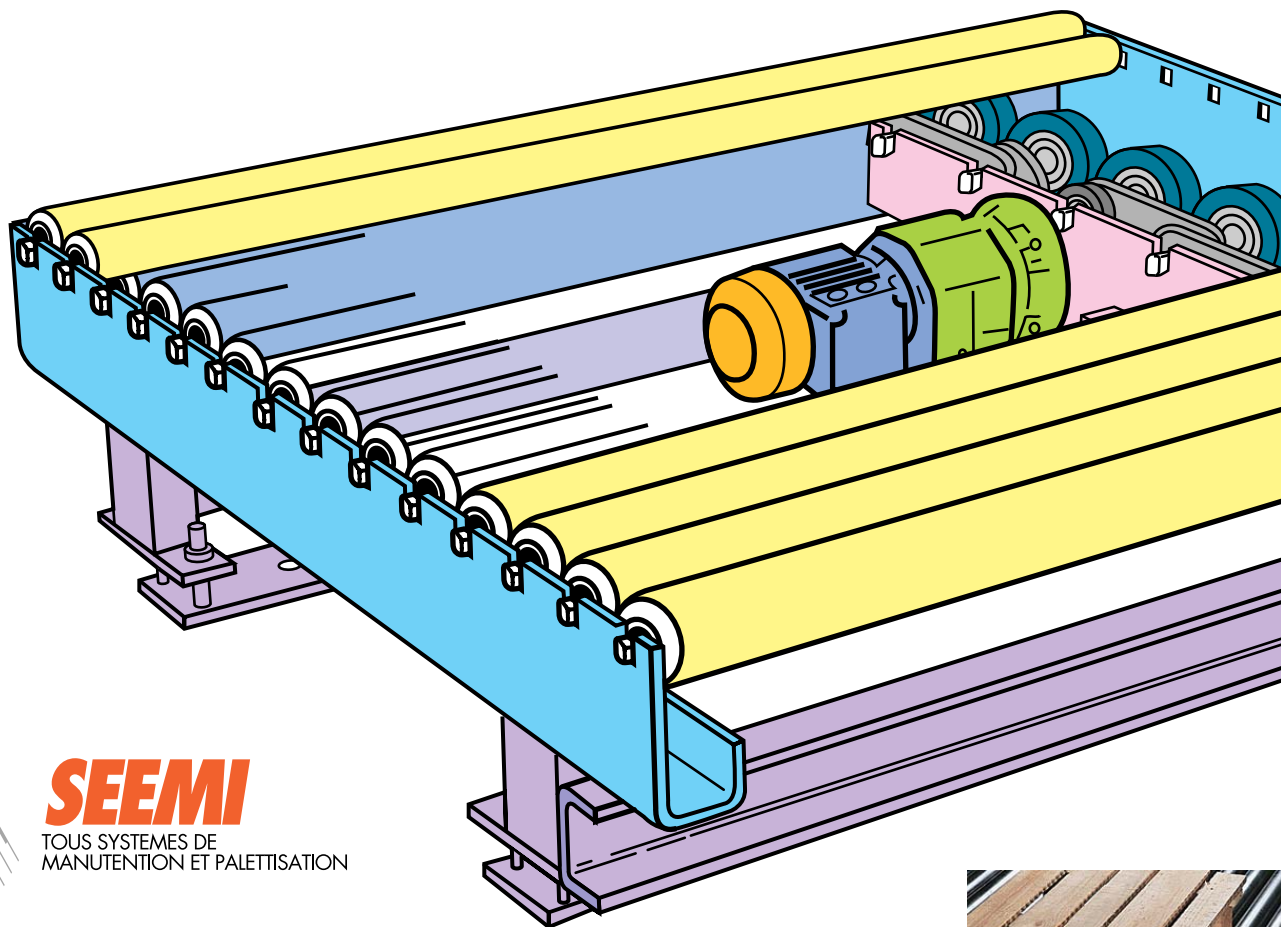

SEEMI

TOUS SYSTEMES DE
MANUTENTION ET PALETTISATION

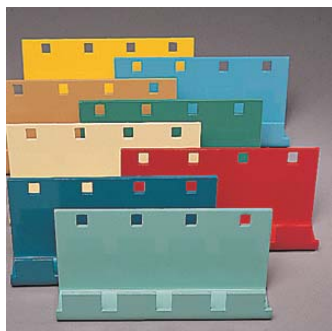

A vos couleurs

With your own colours



Hauteur facilement réglable

Easily adjustable height

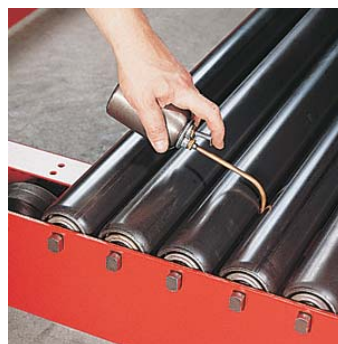

Un graissage propre
et facile de la chaîne

Clean and easy greasing of chain

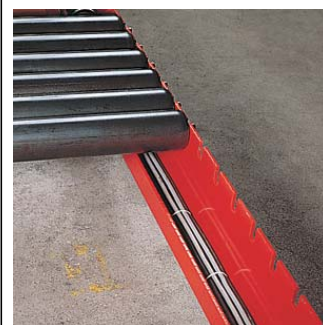

Le passage aisé et propre des gaines électriques

Easy and clean passageway for electric wires

Différents contrôles d'arrêts des charges transportées...

Different stopping controls of the conveyed loads...



Cellule en barrage
Photocell in barrage



Cellule sous les rouleaux
avec rouleau encoché
*Photocell under rollers
with a notched roller*



Capteur fin de course
à positionnement réglable
Switch with adjustable positioning

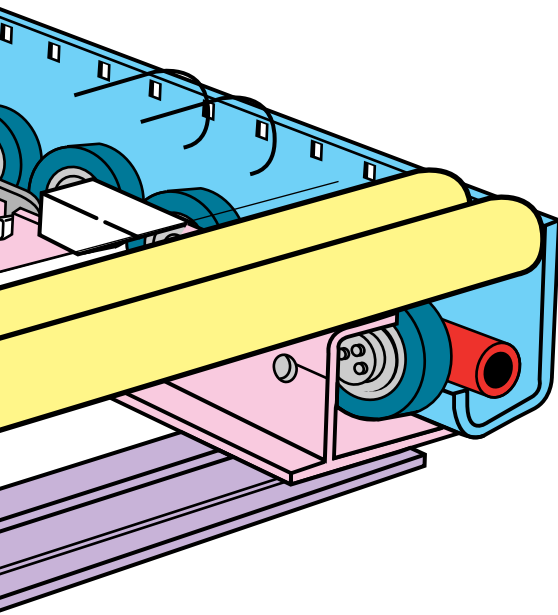

Démontage aisé
Easy dismantling

Rouleaux débrayables
Declutching rollers

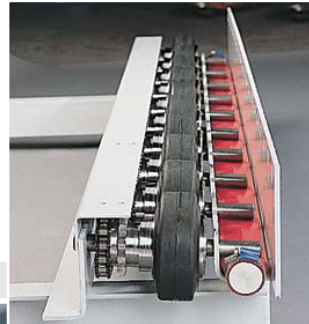

Le pas adapté des rouleaux permet la circulation des palettes dans toutes les directions.

Adapted pitch of rollers enables movement of pallets in all directions.

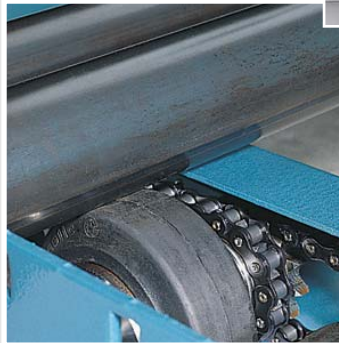

Motorisation des rouleaux par le système **SEEMI** à galets caoutchoutés. Ce système permet un démarrage et un arrêt progressif de la charge transportée.

*Roller driven by the **SEEMI** system with rubber wheels. This system enables a progressive soft start and stop of the transported load.*



Motoréducteur d'entraînement
Geared motor

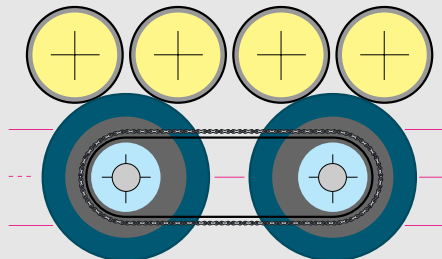

Equipements...

Equipments...



Transmission à chaîne
Chain transmission



Plinthe de protection fin de voie
Protection at end of track



Poutre de compression
Reinforcing girder



Poutre-support (grande largeur)
Support girder (wide conveyor)



Passage piétons
Pedestrian walkway