

UNIWRAP 200 AUTO

Fully automatic pallet wrapping machine

UNITECH®
AUTOMATIC PACKAGING SYSTEMS



UNIWRAP 200 AUTO

Fully automatic pallet wrapping machine

DESCRIZIONE



Macchina fasciatrice automatica a tavola rotante per l'avvolgimento di carichi pallettizzati con film estensibile o rete.

La costruzione particolarmente robusta e l'utilizzo di componenti di primaria qualità la rendono estremamente affidabile nel tempo con minimi costi di manutenzione. L'utilizzo delle più moderne tecnologie consente pieno controllo della pressione esercitata dal film sul prodotto da avvolgere, della percentuale di pre-stiro del film utilizzato e della forza di contenimento totale desiderata.

DESCRIPTION



Fully automatic turntable machine, for pallet wrapping with stretch film or plastic net.

Its robust build and the use of high quality components allow the machine to be extremely reliable in the long term, which minimizes maintenance costs. The use of the most advanced technologies provides total control over the pressure applied by the stretch film over the product, the pre-stretch ratio and the packaging overall holding force.

DESCRIPTION



Machine avec table tournante entièrement automatique, pour banderolage de palettes avec film étirable ou filet.

D'une construction solide et utilisant des composants de très haute qualité nos machines sont extrêmement fiables et durables et vous permettent ainsi de réduire les coûts affiliés à la maintenance. L'utilisation des technologies les plus avancées nous permet un contrôle total de la force de dépose, du taux de tension du film étirable et du maintien de la charge renforcé par le plissage.

DESCRIPCIÓN



Máquina enfundadora automática de mesa rotante para el embalaje de unidades de carga paletizadas con film estirable o red.

La construcción particularmente robusta y el uso de componentes de alta calidad, permiten que la máquina sea extremadamente confiable a lo largo del tiempo, con lo que los gastos de mantenimiento son muy bajos. La utilización de las tecnologías más modernas permite el control total de la presión ejercida del film sobre el producto, del porcentaje de pre-estiraje del film utilizado y de la fuerza de contención del embalaje.



UNIWRAP 200 AUTO

OPTIONS

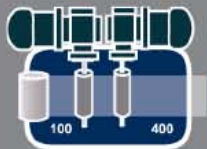

Prestiro motorizzato per carichi leggeri e/o instabili
Powerred prestretch for light or unstable loads
Pré étirage motorisé pour charges légères et/ou instables
Pre-estiro motorizado para cargas ligeras o inestable



Controllo pneumatico della tensione
Pneumatic tension control
Contrôle pneumatique de la tension
Control neumático de la tensión



Saldatore
Electric welding
Souder électriques
Soldador



Sollevatore idraulico
Hydraulic lifter
Table élévatrice hydraulique
Mesa elevadora



Altezza bobina > 500 / 750 mm
Roll height > 500 / 750 mm
Laize bobine > 500 / 750 mm
Altura bobina film > 500 / 750 mm

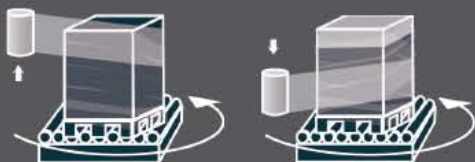

UNIWRAP 200 AUTO

Fully automatic pallet wrapping machine



UNITECH
AUTOMATIC PACKAGING SYSTEMS

UNIWRAP 200 AUTO LAYOUT

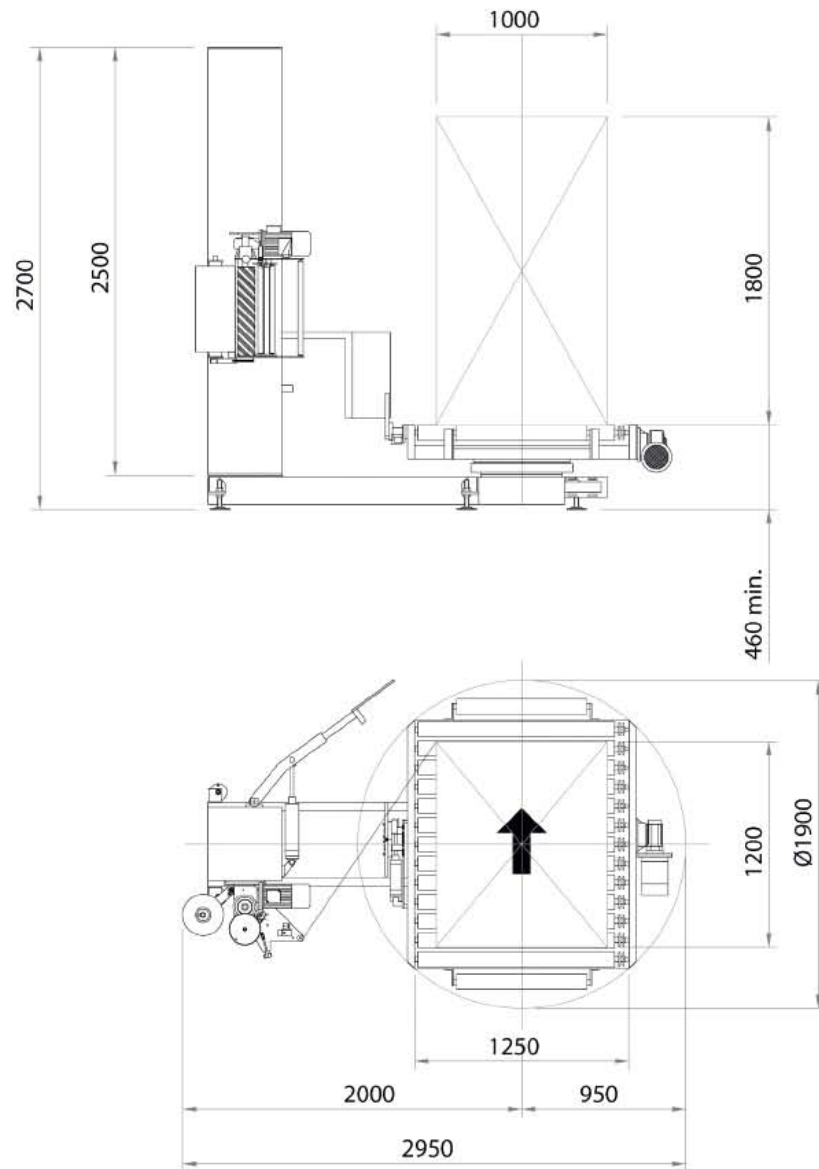

UNIWRAP 200 AUTO STANDARD TECHNICAL DATA

DATI TECNICI STANDARD:	STANDARD TECHNICAL DATA:	DONNÉES TECHNIQUES STANDARD:	DATOS TECNICOS ESTANDAR:	
Altezza bobina	Roll height	Laize bobine	Ancho bobina	500 + 750 mm.
Diametro bobina	Roll diameter	Diamètre bobine	Diámetro bobina	Ø 300 mm. max.
Diametro interno	Internal roll diameter	Diamètre interne	Diámetro interno del mandril	Ø 76 mm.
Spessore	Thickness	Épaisseur	Espesor	13-35 micron
Capacità produttiva	Throughput	Cadence	Capacidad	50 p/h

COMPANY PROFILE

 UNITECH progetta e costruisce macchine fasciatrici ed impianti automatici completi per l'imballaggio e la movimentazione di carichi palettizzati mediante l'utilizzo di films estensibili, termoretraibili e rete tessuta. La decennale esperienza maturata nel settore, l'impiego delle più avanzate tecnologie e di uno staff preparato e dinamico, consentono all'azienda di offrire soluzioni di successo ed innovative alle diverse esigenze del Cliente. L'attiva collaborazione con qualificate aziende di engineering e costruzione di macchine industriali complementari è garanzia di serietà e puntualità nei termini di consegna. Il servizio assistenza garantisce rapidità di intervento e professionalità nell'esecuzione delle ispezioni tecniche atte ad aggiornare tecnologicamente gli impianti.

 Unitech designs and manufactures machines and fully automated lines for wrapping and conveying of palletised loads. We supply stretch wrapping, shrink wrapping and plastic net wrapping systems. Our experience of over 15 years, state-of-the-art technology and a dynamic technical team enable us to provide innovative and successful solutions to satisfy the diverse and wide range of our customers' needs. An active collaboration with qualified engineering and manufacturing groups helps us guarantee on-time and on-budget delivery of our systems. Our experienced technical group provides a prompt and professional field service during installation, commissioning, inspections, and system updates and upgrades.



 Unitech diseña y construye máquinas envasadoras e instalaciones automáticas completas para el embalaje y movimiento de cargas paletizadas mediante el uso de película estirable, termorretráctil y malla tejida. Nuestra experiencia de más de 15 años en el sector, el uso de la más avanzada tecnología y el dinamismo de nuestro personal técnico nos permiten ofrecer soluciones innovadoras y exitosas para las diversas exigencias de nuestros clientes. La activa colaboración con grupos calificados de ingeniería y construcción de maquinaria industrial complementa y garantiza la seriedad y puntualidad en los plazos de entrega. Nuestro servicio de asistencia garantiza la rapidez en la intervención y profesionalismo en la ejecución de los servicios de instalación, puesta en marcha, inspecciones técnicas y la actualización tecnológica de las instalaciones.

 UNITECH conçoit et fabrique des systèmes d'implantation automatique de banderoleuse pour l'emballage et la manutention de charges palettisées avec du film étirable et filet. Notre Société offre des solutions innovatrices pour faire face aux différentes exigences de nos clients et ce, grâce à une expérience de plus de 15 ans dans le secteur de l'emballage, avec l'utilisation de technologies nouvelles et une équipe d'ingénieurs dynamique. Une intense collaboration avec d'autres sociétés d'ingénierie et de construction de machines industrielles complémentaires, garantit fiabilité et ponctualité dans la fourniture de nos systèmes. Notre assistance technique assure aux clients une rapidité d'intervention et un professionnalisme pour la mise en place de nouveaux contrôles et la mise au jour d'implantations existantes.

